

## Modular Cooking Range Line EVO700 Gas Solid Top on Gas Oven with 2 Burners and Cupboard

ITEM # \_\_\_\_\_

MODEL # \_\_\_\_\_

NAME # \_\_\_\_\_

SIS # \_\_\_\_\_

AIA # \_\_\_\_\_



372010 (Z7STGL3010)

Gas solid top (7 kW) with 2  
burners (5,5 kW each), on gas  
oven (6 kW) and open  
cupboard base, 1200mm

### Short Form Specification

#### Item No.

High efficiency 7 kW central burner, flame failure device and protected pilot light. Suitable for natural gas or LPG. Large cooking surface with different heating zones. Large flat cooking surface made in cast iron allows for the use of a number of various sized pots and pans, all easily moved across the surface without lifting. Stainless steel oven chamber with 3 levels of runners to accommodate 2/1 GN shelves (2 steam pans). Two high efficiency 5,5 kW flower flame burners with continuous power regulation and protected pilot light interchangeable on site. Flame failure device as standard on burners to protect against accidental extinguishing. Exterior panels in stainless steel with Scotch Brite finish. One piece pressed work top in 1.5 mm thick stainless steel. Right-angled side edges to allow flush-fitting junction between units.

### Main Features

- Gas heated, 7 kW central burner, solid top.
- Durable cast iron cooking plate, easy to clean.
- The center of the plate can reach a maximum temperature of 500 °C while decreasing outwards.
- Central burner with optimized combustion, flame failure device and protected pilot light.
- Temperature gradients to satisfy different cooking needs, provided over the whole plate thanks to the temperature fine-tuning by zone.
- Various sizes of pans can be used at the same time due to large surface area with no intermediate sectors.
- Pans can easily be moved from one area to another without lifting.
- Base compartment consists of a gas heated standard oven with stainless steel burners and self stabilizing flame positioned beneath the base plate. Stainless steel oven chamber to have 3 levels of runners to accommodate 2/1 GN shelves (2 steam pans) and ribbed enamelled steel base plate.
- Oven thermostat adjustable from 110 °C to 270 °C.
- Burners with optimized combustion interchangeable on site.
- Flame failure device on each burner protects against gas leakage when accidental extinguishing of the flame occurs.
- Cupboard compartment for storage of pots, pans, sheet pans etc.
- All major compartments located in front of unit for ease of maintenance.
- IPX4 water resistance certification.

### Construction

- All exterior panels in Stainless Steel with Scotch Brite finishing.
- One piece pressed 1.5 mm work top in Stainless steel.
- Model has right-angled side edges to allow flush fitting joints between units, eliminating gaps and possible dirt traps.

APPROVAL: \_\_\_\_\_

### Included Accessories

- 1 of GN2/1 chrome grid for static oven PNC 164250

### Optional Accessories

- GN2/1 chrome grid for static oven PNC 164250
- Junction sealing kit PNC 206086
- Draught diverter, 150 mm diameter PNC 206132
- Matching ring for flue condenser, 150 mm diameter PNC 206133
- 4 wheels, 2 swivelling with brake (EVO700/900). It is mandatory to install with base supports for feet/wheels. PNC 206135
- Flanged feet kit PNC 206136
- Frontal kicking strip for concrete installation, 1200 mm PNC 206151
- Frontal kicking strip for concrete installation, 1600 mm PNC 206152
- Frontal kicking strip, 1200 mm PNC 206178
- Frontal kicking strip, 1600 mm PNC 206179
- Frontal handrail 1200 mm PNC 206191
- Frontal handrail 1600 mm PNC 206192
- 4 feet for concrete installation (not for 900 line freestanding grill) PNC 206210
- Right and left side handrails PNC 206240
- 2 supports with side runners for 4 GN 1/1 containers for open base cupboards (multifunctional cookers, solid top and gas ranges with cupboard) PNC 206244
- Flue condenser for 1 module, 150 mm diameter PNC 206246
- Pair of side kicking strips PNC 206249
- Electric heating kit for cupboards PNC 206259
- Single burner smooth plate for direct cooking - fits frontal burners only PNC 206260
- Single burner ribbed plate for direct cooking- fits frontal burners only PNC 206261
- Single burner radiant plate for pan support PNC 206264
- Pair of side kicking strips (concrete installation) PNC 206265
- Water column with swivel arm (water column extension not included) PNC 206289
- Water column extension PNC 206291
- Stainless steel grid for 2 burners PNC 206297

- Chimney upstand, 1200 mm PNC 206306
- 2 side covering panels, height 700 mm, depth 700 mm PNC 206319
- Door for open base cupboard PNC 206342
- 2 drawers for open base, height 100 mm PNC 206360
- Wok pan support for open burners (EVO700/900) PNC 206363
- Base support for feet or wheels - 1200mm (EVO700/EVO900) PNC 206368
- Base support for feet or wheels - 1600mm (EVO700/900) PNC 206369
- Rear paneling - 1200mm (EVO700/900) PNC 206376
- Kit town gas nozzles (G150) for EVO700 solid top and burner PNC 206388
- Double burner smooth plate for direct cooking PNC 921684
- Double burner ribbed plate for direct cooking PNC 921685
- Pressure regulator for gas units PNC 927225

**Front**

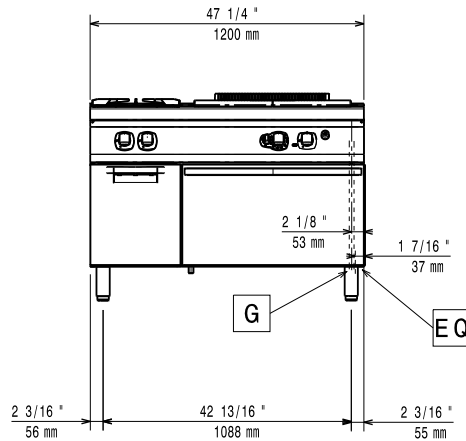

**Side**

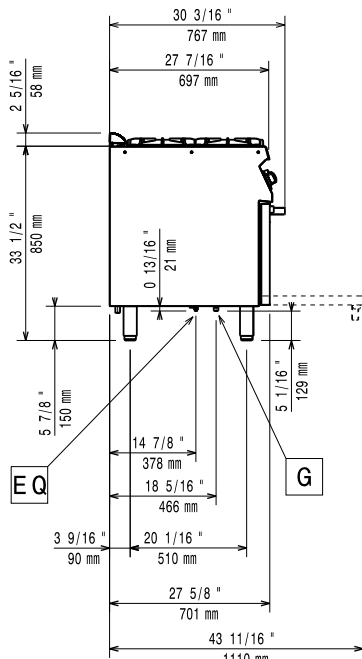

**EQ** = Equipotential screw  
**G** = Gas connection

**Top**

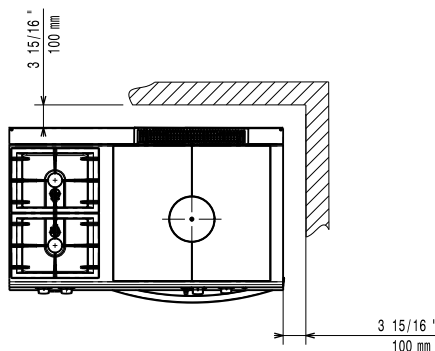

**Gas**

<b>Gas Power:</b>	
372010 (Z7STGL3010)	24 kW
<b>Standard gas delivery:</b>	Natural Gas G20 (20mbar)
<b>Gas Type Option:</b>	LPG
<b>Gas Inlet:</b>	1/2"

**Key Information:**

<b>Front Burners Power:</b>	5.5 - kW
<b>Back Burners Power:</b>	5.5 - 0 kW
<b>Back Burners Dimension - mm</b>	Ø 60
<b>Front Burners Dimension - mm</b>	Ø 60
<b>Solid top usable surface (width):</b>	690 mm
<b>Solid top usable surface (depth):</b>	590 mm
<b>Oven working Temperature:</b>	110 °C MIN; 270 °C MAX
<b>Oven Cavity Dimensions (width):</b>	540 mm
<b>Oven Cavity Dimensions (height):</b>	300 mm
<b>Oven Cavity Dimensions (depth):</b>	650 mm
<b>Storage Cavity Dimensions (width):</b>	330 mm
<b>Storage Cavity Dimensions (height):</b>	420 mm
<b>Storage Cavity Dimensions (depth):</b>	640 mm
<b>Net weight:</b>	140 kg
<b>Shipping weight:</b>	160 kg
<b>Shipping height:</b>	1140 mm
<b>Shipping width:</b>	1300 mm
<b>Shipping depth:</b>	820 mm
<b>Shipping volume:</b>	1.22 m <sup>3</sup>

If appliance is set up or next to or against temperature sensitive furniture or similar, a safety gap of approximately 150 mm should be maintained or some form of heat insulation fitted.